

型号(Type) : **GNYS1300mAh(F)HP**

Specifications of single cell

Nominal voltage		1.2V	
Capacity		0.2C Discharge	1.0C Discharge
	Minimum	300min	54min
	Typical	310min	60min
Dimensions		mm	
	Diameter	23.0 <sup>-1.0</sup>	
	Height	43.0 <sup>-1.0</sup>	
Weight(Approximately)		克 gram 40.0	
Internal Impedance At 1000 Hz		12mΩ(Max) ( After Charge )	
Charge	Standard	130mA(0.1C)×15hrs	
	Rapid	1300mA(1.0C)×1.2hrs	
Ambient temperature	Charge		°C
		standard	0°C to 45°C
		Rapid	0°C to 40°C
	Discharge	-20°C to 50°C	
	Storage	-20°C to 40°C	

PVC (Dimensions with PVC of single cell)

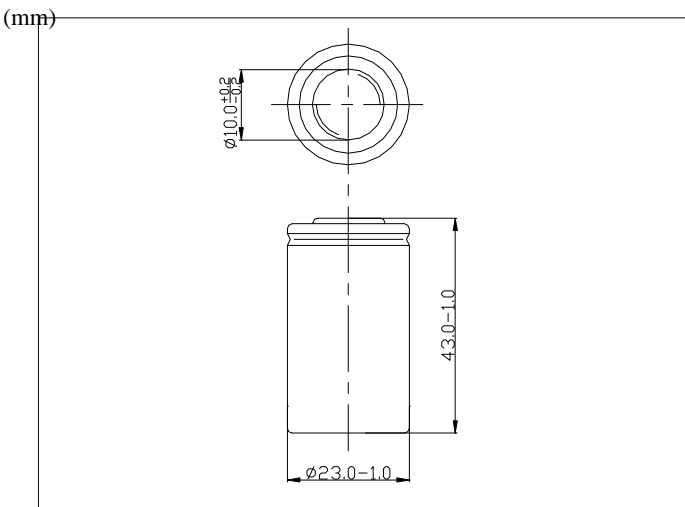

Note:

1. Nominal capacity, rated at 0.2C 20°C.
2. Weight are For reference.
3. Standard according as IEC of test cycle life.

Typical characteristics

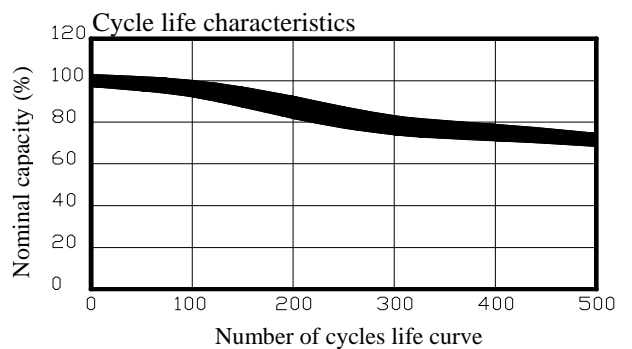
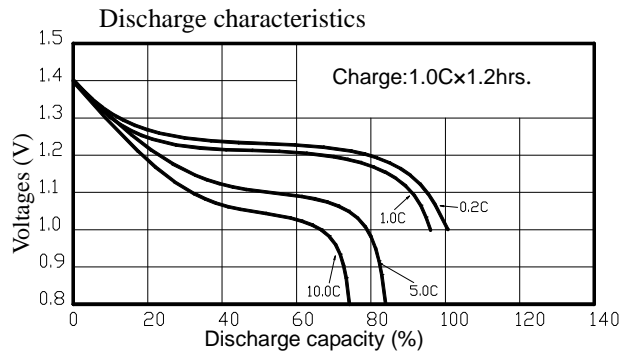
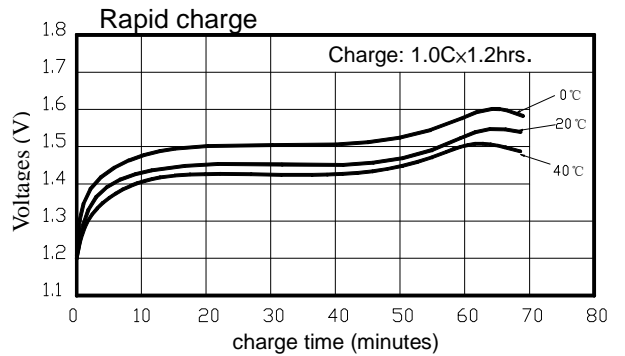
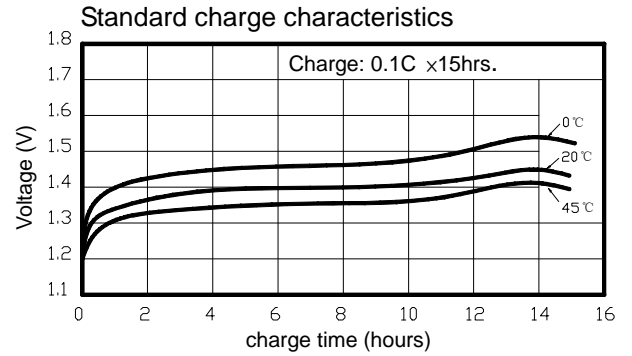

Ni-Cd

Charge retention curves of Ni-Cd cylindrical cell at various storage temperature

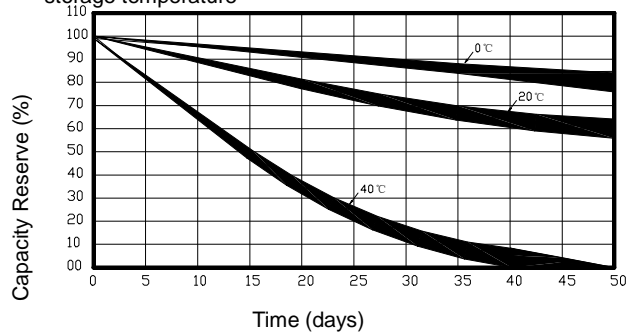

MODEL NO.: Ni-Cd SC1300mAh(F) High Power 1.2V

Description	Unit	Specification	Condition
Nominal Voltage	V	1.2	Unit cell
Typical Capacity	min	310	Standard Charge/Discharge
Nominal Capacity	mAh	1300	Standard Charge/Discharge
Minimum Capacity	min	300	Standard Charge/ Discharge
Standard Charge	mA	130(0.1C)	Ta=0~40°C (see note 1)
	hour	15	
Fast Charge	mA	260(0.2C)~1300(1.0C) with charge termination control	-ΔV=8~10mV/cell Timer cutoff=120% input capacity Temp. cutoff=45°C dT/dt=0.8°C/min(0.5 to 1.0C); 0.8~1°C/min(1C)
	hour	6.5 approx.(0.2C) 1.2 approx.(1.0C)	
Trickle Charge	mA	43(0.03C)~65(0.05C)	Ta=0~40°C (see note 1)
Discharge Cut-off Voltage	V	1.0	Unit cell
Maximum Discharging Current	A	15	Ta =0~50°C 0.7V cut off
Storage Temperature	°C	-20~+25(within 1 year) -20~+30(within 3 month) -20~+40(within 1 month) -20~+50(within 1 week)	*
Typical Weight	g	40.0 approx	*

**5 PERFORMANCE**

Before proceed the following tests, the cells should be discharged at 0.2C to 1.0V cutoff.  
 Unless otherwise stated, tests should be done within one month of delivery under the following conditions:

Ambient temperature:  $20^{\circ}\text{C} \pm 5^{\circ}\text{C}$

Relative Humidity:  $65\% \pm 20\%$

Note Standard Charge/Discharge Conditions:

Charge:  $130\text{mA}(0.1\text{C}) \times 15\text{hrs}$

Discharge:  $260\text{mA}(0.2\text{C})$  to 1.0V/cell

Test	Unit	Specification	Condition	Remarks
Capacity	min	$\geq 300$	Standard Charge / Discharge	Up to 3 cycles are allowed
Open circuit Voltage (OCV)	V	$\geq 1.25$	Within 1 hr after standard charge	Unit cell
Internal Impedance (Ri)	$\text{m}\Omega$	$\leq 12$	Upon fully charge at 1kHz	*
High Rate Discharge (1.0C)	min	$\geq 54$	Standard Charge/rest 30min discharge at 1.0C to 0.9V	允许循环 3 次 Up to 3 cycles are allowed
High Rate Discharge (10.0C)	min	$\geq 4.2$	Standard Charge rest 30min discharge at 10.0C to 0.7V	Up to 3 cycles are allowed
Overcharge	N/A	No conspicuous deformation and/or leakage	0.1C charge for 28 days	*
Charge reserve	min	$\geq 195\text{min}$	Standard charge Storage: 28 days Standard discharge (0.2C)	1.0V/cell Cut-off
IEC Cycle Life Test	Cycle	$\geq 500$	IEC61951-1(2003)7.4.1.1	*

Vibration	N/A	No fire, no explosion and no Leakage.	<p>Fully charged cells are vibration-tested</p> <ul style="list-style-type: none"> <li>-A simple harmonic motion is applied to the cells with an amplitude of 0.76mm (a total maximum excursion of 1.52mm)</li> <li>-The entire range of frequencies:10Hz~55Hz -Traversed time :90min±5min,</li> <li>-The vibration is applied in each of three mutually perpendicular</li> </ul>	*
External Short Circuit	N/A	No fire and no explosion.	<p>Fully charged cells are stored in an ambient temperature of 20°C±5°C,Each cell is then short-circuited by connecting the positive and negative terminals with a total resistance of less than 100mΩ,</p> <p>Stop the test ,whichever is meet</p> <ul style="list-style-type: none"> <li>-the test lasts 24 hours</li> <li>-the case temperature declines by 20% of the maximum temperature rise</li> </ul>	*
Free fall	N/A	No fire and no explosion.	<p>Each fully charged cell is dropped three times from a height of 1.0m onto a concrete floor. The cell are dropped so as to obtain impacts in random orientations.</p>	*
Mechanical Shock(crash hazard)	N/A	No fire, no explosion and no Leakage.	<p>The fully charged cell is secured to the testing machine by mean of a rigid mount. The cell is subjected to a total of three shocks of equal magnitude. The shocks are applied in each of three mutually perpendicular directions. At least one of them shall be perpendicular to a flat face.</p> <p>Test method:</p> <ul style="list-style-type: none"> <li>- The minimum average acceleration is 75g<sub>n</sub> during initial 3 milliseconds. The peak acceleration shall be between 125g<sub>n</sub> and 175g<sub>n</sub></li> </ul>	*
Forced discharge	N/A	No fire and no explosion	<p>Forced discharge at 0.2C to 1.0V,then the current to be increased to 1C and continue for 90 min.</p>	*

Notes:

1. Ta: Ambient Temperature
2. Approximate charge time from discharged state, for reference only.
3. Please activate the battery once every 3 months according to the following method: Charge at 0.1C for 15 hrs, rest 10 min, then discharge with 0.2C to 1.0V/cell.

**6 PRECAUTIONS TO ENSURE THE SAFETY ON BANDING BATTERY**

- 6.1 Batteries should be charged prior to use.
- 6.2 When using a new battery for the first time or after long term storage, please fully charge the battery before use.
- 6.3 For charging methods please reference to our technical hand-book.
- 6.4 Use the correct charger for Ni-Cd or Ni-MH batteries.
- 6.5 Do not reverse charge batteries.
- 6.6 Do not short circuit batteries, permanent damage to batteries may result.
- 6.7 Do not incinerate or mutilate batteries, may burst or release toxic material.
- 6.8 Do not solder directly to cells or batteries.
- 6.9 Do not subject batteries to adverse condition such as extreme temperature, deep cycling and excessive overcharge/overdischarge.
- 6.10 Store batteries in a cool dry place.

- 6.11 Не используйте в аккумуляторной сборке наши аккумуляторные элементы и аккумуляторные элементы других производителей или аккумуляторные элементы другого химического состава. Do not mix our batteries with other battery brands or batteries of a different chemistry such as alkaline and zinc carbon.
- 6.12 Не используйте в аккумуляторной сборке новые аккумуляторные батареи и использованные, возможен переразряд аккумуляторных элементов. Do not mix new batteries in use with semi-used batteries, overdischarge may occur.
- 6.13 Avoid batteries being used in an airtight compartment. Ventilation should be provided inside the battery compartment; otherwise batteries may generate hydrogen gas, which could cause an explosion if exposed to an ignition source.
- 6.14 Подключайте аккумуляторную сборку к зарядному устройству с соблюдением правильной полярности. When connecting a battery pack to a charger, ensure correct polarity.
- 6.15 Немедленно прекратите использовать батарею если есть подозрительный звук, чрезмерно высокая температура или протечка батареи. If find any noise, excessive temperature or leakage from a battery, please stop its use.
- 6.16 Если батарея горячая, пожалуйста, не трогайте и не переносите ее, пока она не остынет. When the battery is hot, please do not touch it and handle it, until it has cooled down.
- 6.17 Do not remove the outer sleeve from a battery pack nor cut into its housing.
- 6.18 Если аккумулятор разряжен выключите питаемое устройство во избежании переразряда аккумулятора. When find battery power down during use, please switch off the device to avoid overdischarge.
- 6.19 Если батарея не используется, отключите от него питаемое устройство. When not using a battery, disconnect it from the device.
- 6.20 Unplug a battery by holding the connector itself and not by pulling at its cord.
- 6.21 After use, if the battery is hot, before recharging it, allow it to cool in a well-ventilated place out of direct sunlight.
- 6.22 Не помещайте батарею в воду или морскую воду. Never put a battery into water or seawater.
- 6.23 Во время продолжительного хранения батареи необходимо заряжать и разряжать раз в 3 месяца. During long term storage, battery should be charged and discharged once every 3 months.
- 6.24 Не пытайтесь разбирать, давить или ударять аккумуляторные элементы. Это может вызвать их нагрев или возгорание. Do not attempt to take batteries apart or subject them to pressure or impact. Heat may be generated or fire may result. The alkaline electrolyte is harmful to eyes and skin, and it may damage clothing upon contact.

Держите от детей, при попадании в желудок немедленно обратитесь к врачу. Keep away from children. If swallowed, contact a physician at once.

**Append:** IEC61951-1 7.4.1.1 Endurance in cycles

Before the endurance in cycles test, the cell shall be discharged at 0.2C to a final voltage of 1.0V/cell. The following endurance test shall then be carried out, irrespective of cell designation, in an ambient temperature of  $20^{\circ}\text{C} \pm 5^{\circ}\text{C}$ . Charge and discharge shall be carried out at constant current throughout, using the conditions specified in table 4. Precautions shall be taken to prevent the cell-case temperature from rising above  $35^{\circ}\text{C}$  during the test, by providing a forced air draught if necessary.

NOTE-Actual cell temperature, not the ambient temperature, determines cell performance.

**Table 4 Endurance in cycles**

Cycle number	Charge	Stand in Charged condition	Discharge
1	0.1C for 16h	None	0.25C for 2h20min <sup>a</sup>
2 to 48	0.25C for 3h10min	None	0.25C for 2h20min <sup>a</sup>
49	0.25C for 3h10min	None	0.25C to 1.0V/cell
50	0.1C for 16h	1h to 4h	0.2C to 1.0V/cell <sup>b</sup>
a If cell discharge voltage drops below 1.0V/cell, discharge may be discontinued. b It is permissible to allow sufficient open-circuit rest time after the completion of discharge at cycle 50, so as to start cycle 51 at an exact two-week interval. A similar procedure may be adopted at cycles 100, 150, 200, 250, 300, 350, 400 and 450.			

Cycles 1 to 50 shall be repeated until the discharge duration on any 50<sup>th</sup> cycle becomes less than 3h at this stage, a further cycle as specified for cycle 50 shall be carried out. The endurance test is considered complete when two such successive cycles give a discharge duration less than 3h. The number of cycles obtained when the test is completed shall be not less than 500.